

**GAUTENG DEPARTMENT OF EDUCATION  
PROVINCIAL EXAMINATION  
NOVEMBER 2020  
GRADE 9**

**NATURAL SCIENCES**

**NAME OF LEARNER:** \_\_\_\_\_

**GRADE 9:** \_\_\_\_\_

**NAME OF SCHOOL:** \_\_\_\_\_

**MARKS: 100**

**TIME: 2 hours**

**17 pages**

QUESTIONS	1	2	3	4	5	6	7	8	9	10	11	TOTAL
LEARNER'S MARKS												
MARKS	8	6	6	8	10	7	5	17	10	16	7	100

**INSTRUCTIONS AND INFORMATION**

1. Write your name, surname and class on the cover page of the question paper that serves as an ANSWER SHEET.
2. Answer all questions in the spaces provided.
3. This question paper consists of SECTION A, SECTION B and SECTION C based on the prescribed content framework in the CAPS document.
4. Allocation of marks:  
  
SECTION A [20]  
SECTION B [30]  
SECTION C [50]
5. This question paper consists of eleven questions and seventeen pages.
6. All drawings should be done in pencil and labelled in blue or black ink.
7. Write neatly and legibly.

## SECTION A

## QUESTION 1: MULTIPLE CHOICE QUESTIONS

Various options are provided as possible answers to the following questions. Each question has only ONE correct answer. Choose the correct option and write the correct letter (A – D) in the blocks provided.

- 1.1 A ball is thrown into the air and falls back to earth.  
The force that makes it fall is...

A magnetic force.  
B friction force.  
C gravitational force.  
D electrostatic force.

(1)

- 1.2 A simple device that opens and closes a circuit is known as a ...

A cell.  
B switch.  
C battery.  
D rheostat.

(1)

- 1.3 Which of the ammeters in the circuit below will have the same reading?  
Note that all cells are identical and all bulbs are identical.

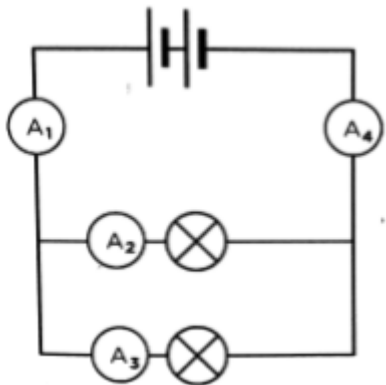

A A1 and A4  
B A1 and A2  
C A4 and A2  
D A4 and A3

(1)

1.4 Lightning is an application of ...

- A magnetic forces.
- B electrostatic forces.
- C gravitational forces.
- D tension forces.

(1)

1.5 The substances before an arrow in a chemical reaction equation are called ...

- A products.
- B acids.
- C bases.
- D reactants.

(1)

1.6 A property of an acid:

- A feels soapy
- B bitter taste
- C neutral pH
- D sour taste

(1)

1.7 The reaction of magnesium (metal) with oxygen will always give a product ...

- A magnesium salts.
- B magnesium hydroxides.
- C magnesium oxides.
- D magnesium dioxides.

(1)

1.8 The circuit form suitable for electric wiring in a house.

- A Series circuit
- B Parallel circuit
- C Both parallel and series
- D Neither one of the two circuits

(1)

[8]

**QUESTION 2****TERMINOLOGY**

Give the correct scientific term for each of the following descriptions. Write only the term in the space provided.

2.1 A force that results when two objects are in contact with each other is called a ...

\_\_\_\_\_ (1)

2.2 The arrangement of all known elements based on their atomic number and chemical properties.

\_\_\_\_\_ (1)

2.3 The component that opposes the flow of a current in an electrical circuit.

\_\_\_\_\_ (1)

2.4 The number of protons and neutrons in the nucleus of an atom.

\_\_\_\_\_ (1)

2.5 The process that takes place when an acid reacts with a base.

\_\_\_\_\_ (1)

2.6 A compound formed when carbon reacts with oxygen.

\_\_\_\_\_ (1)  
**[6]**

**QUESTION 3****MATCHING ITEMS**

Choose an item from COLUMN B that matches the statement in COLUMN A. Write only the letter (A – H) next to the question number (3.1 to 3.6) in the space provided.

COLUMN A	COLUMN B	ANSWER
3.1 A safety device in an electric circuit that melts if the current exceeds a safety level	A Circuit breaker	3.1 _____
3.2 New substances that form in a chemical reaction	B Universal indicators	3.2 _____
3.3 A substance that changes into a range of colours in different solutions in which it is placed, depending on the pH of the solution	C Ohms	_____
3.4 Electric resistance is measured in ...	D Products	3.3 _____
3.5 A safety device that automatically switches off the flow of an electrical current when an overload or short circuit occurs	E Atomic Mass Number	3.4 _____
3.6 The elements in the Periodic Table of Elements are placed in the increasing order of their ...	F Fuse	3.5 _____
	G Conductor	3.6 _____
	H Atomic number	_____

[6]

TOTAL SECTION A: 20

## SECTION B

## MATTER AND MATERIALS

## QUESTION 4

## THE PERIODIC TABLE OF ELEMENTS AND COMPOUNDS

Use the attached Periodic Table of Elements and answer the following questions.

4.1 Write down ONE semi-metal in period 2.

\_\_\_\_\_ (1)

4.2 Write down the name of the element in group 16, period 2.

\_\_\_\_\_ (1)

4.3 Provide the name of the element that has 10 protons.

\_\_\_\_\_ (1)

4.4 Give the atomic number of magnesium.

\_\_\_\_\_ (1)

4.5 Give the atomic mass number of chlorine.

\_\_\_\_\_ (1)

4.6 A compound is written  $\text{SO}_3$ . Write all the information that is conveyed by this formula.

\_\_\_\_\_  
\_\_\_\_\_  
\_\_\_\_\_  
\_\_\_\_\_  
\_\_\_\_\_

(3)  
[8]

## QUESTION 5

## CHEMICAL REACTIONS

- 5.1 Hydrogen reacts with oxygen to form water. Use the key below and provide a picture equation for the following reaction.

KEY



Hydrogen



Oxygen

(4)

- 5.2 Write down a balanced chemical equation of the reaction for your answer in QUESTION 5.1.

(4)

- 5.3 Balance the following chemical equation.



(2)

[10]



**QUESTION 6****REACTION OF METALS AND NON-METALS WITH OXYGEN**

Rust is a natural process that occurs naturally in nature and its effects can be quite beautiful but also very harmful and dangerous.

6.1 What is rusting and how is it undesirable for us?

---

---

---

(2)

6.2 How can we prevent the rusting of iron? Provide only TWO ways of prevention.

---

---

(2)

6.3 A person is sleeping in a room with a coal fire lit in it. All the doors and windows are closed in the room. Is this a healthy situation in your opinion? Motivate your answer.

---

---

---

(3)

**[7]**

## QUESTION 7

## ACIDS, BASES AND THEIR pH VALUES

The following graph represents the pH values of different household substances. Study the graph and answer the questions that follows.

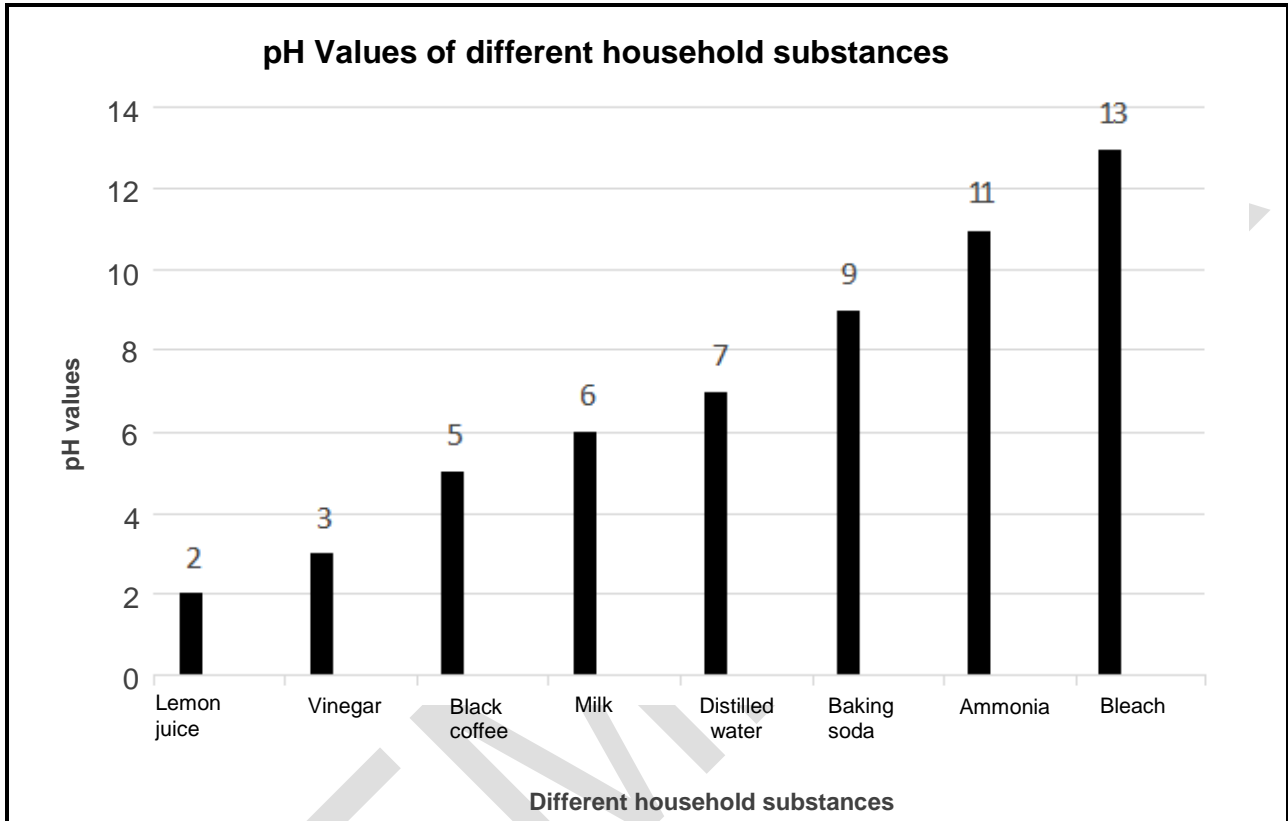

7.1 What type of graph is represented here?

---

(1)

7.2 Name the substance that is most acidic on the graph.

---

(1)

7.3 Predict what will happen if you add vinegar to baking soda.

---

(1)

7.4 What will the pH value be of the substance in QUESTION 7.3 that will form?

---

(1)

7.5 Which colour will the substance in QUESTION 7.3 be on the universal indicator?

---

(1)

[5]

**TOTAL SECTION B: 30**

P.T.O.

**SECTION C**

**ENERGY AND CHANGE**

**QUESTION 8**

**FORCES**

8.1 A boy tries to pull a heavy stone across surface. Mention the various forces that will act on the stone.

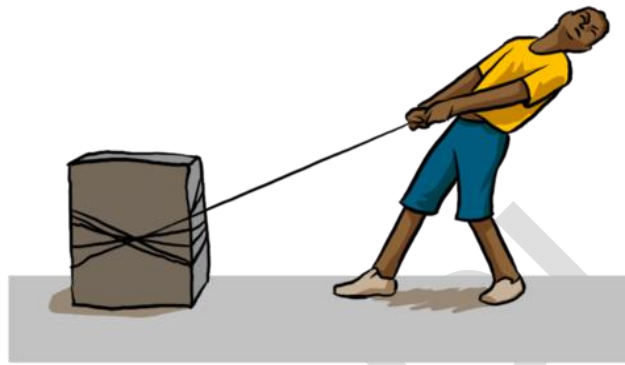

---



---



---



---



---

(5)

8.2 A balloon is rubbed against a jersey and the balloon becomes negatively charged.

8.2.1 Explain what “negatively charged” means.

---

(2)

8.2.2 Explain where the negative charge comes from. (Refer to both protons and electrons in your answer.)

---



---



---

(4)

8.3 Name the type of force that the balloon and the jersey experience AFTER rubbing.

---

(1)

8.4 Will the force referred to above be an attractive or repulsive force?

---

(1)

8.5 Explain what is meant by electrostatic force.

---

---

---

(2)

8.6 Compare TWO points of difference between electrostatic force and gravitational force.

Electrostatic force	Gravitational force
1.	1.
2.	2.

(2)

[17]

**QUESTION 9****ELECTRICAL CELLS AS ENERGY SYSTEMS**

Acidic fruits such as lemons can be used as a cell in electrical circuits as shown below. The fruit is gently squeezed to soften the fruit so that the juice is released inside while ensuring that the lemon peel does not break.

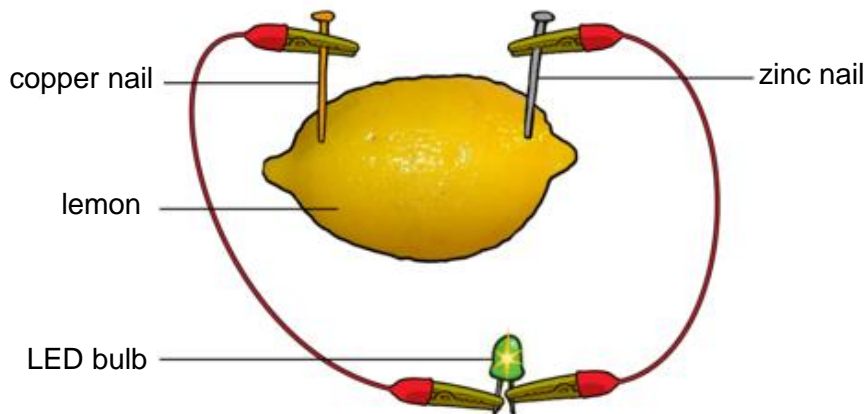

9.1 Define the term electrolyte.

---

---

---

(2)

9.2 What is the function of the LED bulb in the circuit diagram above?

---

---

(2)

9.3 Draw a diagram of a symbol of a cell in the electrical circuit.

(2)

9.4 Differentiate between a cell and a battery in an electrical cell.

Cell	Battery

(2)

9.5 State the function of the acid inside the lemon in the above cell.

---

---

(2)  
[10]

### QUESTION 10

#### RESISTANCE

Learners investigated the effect of the length of a conductor on its resistance. They used five copper wires of different lengths and recorded ammeter readings for each length.

The table below shows the results they recorded.

LENGTH OF WIRE (cm)	READING ON AMMETER (Ampere)
3	5
6	4
9	3
12	2
15	1

10.1 Plot a line graph of the length of the conductor against the current in the space provided.

(4)



10.2 Provide an aim for this experiment.

---

---

(2)

10.3 Describe the pattern shown by the graph.

---

---

---

(2)

10.4 Interpret the pattern in terms of the length of the conductor and the resistance.

---

---

---

(2)

10.5 Predict a hypothesis for this experiment.

---

---

(2)

10.6 Identify the:

10.6.1 Dependent variable:

---

---

(1)

10.6.2 Independent variable:

---

---

(1)

10.7 Using the results from the graph what will your conclusion be?

---

---

---

(2)

**[16]**

## QUESTION 11

## SERIES AND PARALLEL CIRCUITS AND SAFETY WITH ELECTRICITY

11.1 Consider the following circuit diagram. All light bulbs are identical.

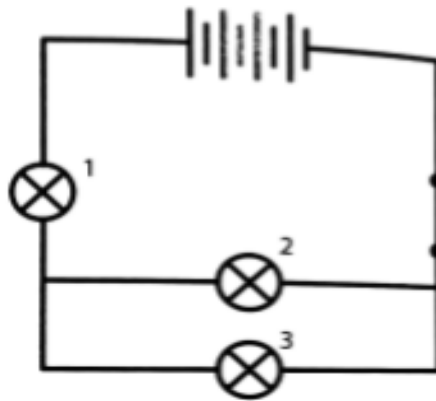

11.1.1 If the voltage of one cell is 3V, determine the voltage of the battery.

\_\_\_\_\_ (2)

11.1.2 State what you know about the current through light bulbs 2 and 3.

\_\_\_\_\_  
\_\_\_\_\_ (1)

11.1.3 If lightbulb 1 blows, what will happen to lightbulb 3? Explain your answer.

\_\_\_\_\_ (2)



11.2 Answer the question based on the diagram below.

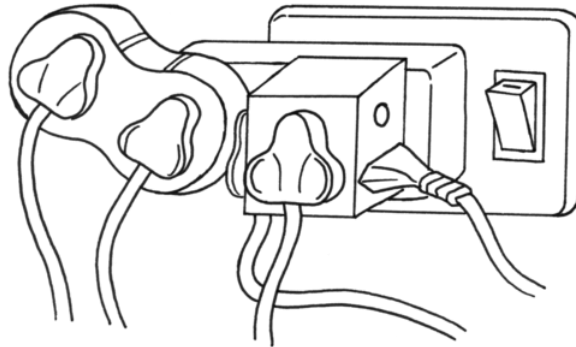

Why does connecting too many appliances in a single plug cause overloading?

---

---

---

(2)

[7]

**TOTAL SECTION C: 50**

**TOTAL: 100**

**END**