



Province of the
EASTERN CAPE
EDUCATION

SENIOR PHASE

GRADE 9

NOVEMBER 2018

MATHEMATICS

MARKS: 140

TIME: 2½ hours



This question paper consists of 18 pages, including 2 annexures.

INSTRUCTIONS AND INFORMATION

1. Read the instructions for each question carefully before answering the questions.
2. This paper consists of NINE questions.
3. Answer ALL the questions.
4. Number your answers exactly as the questions are numbered in the question paper.
5. You may use an approved scientific calculator (non-programmable and non-graphical).
6. Clearly show ALL the calculations, diagrams and graphs etc. you have used in determining your answers.
7. Diagrams are NOT necessarily drawn to scale.
8. Write neatly and legibly.

QUESTION 1

Various options are given as possible answers to the following questions. Choose the answer and write only the letter (A–D) next to the question number, for example if the correct answer for 1.1 is A, write your answer as 1.1 A.

1.1 Which ONE of the following numbers is irrational?

- A $3,\dot{7}$
- B $\sqrt[3]{-27}$
- C $-\sqrt{3}$
- D $\sqrt{1\frac{7}{9}}$

(1)

1.2 When $\frac{3^x \cdot 3^{x+3}}{3^{x+2}}$ is simplified, the answer is:

- A 3^{x+1}
- B 3^{x+5}
- C 3^x
- D $\frac{9^{2x+3}}{3^{x+2}}$

(1)

1.3 The equation of the straight line drawn below is:

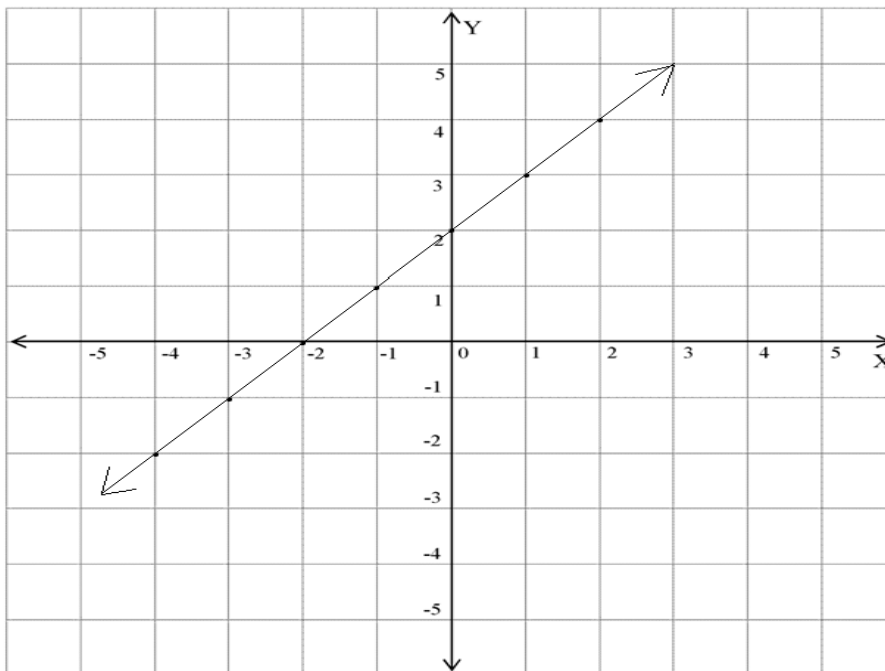

- A $y = 2x - 2$
- B $y = x + 2$
- C $y = -2x + 2$
- D $y = -x - 2$

(1)

1.4 If $x(2x - 8) = 0$, then x is:

- A 0 or 4
 - B 0 or -4
 - C 2 or -2
 - D None of the above
- (1)

1.5 The general rule (T_n) for the pattern $-5 ; -1 ; 3 ; 7 ; \dots$ is:

- A $T_n = 4n + 9$
 - B $T_n = -4n - 9$
 - C $T_n = -4n + 9$
 - D $T_n = 4n - 9$
- (1)

1.6 The value (in scientific notation) of $5,2 \times 10^{-5} \times 3 \times 10^3$ is:

- A $15,6 \times 10^{-1}$
 - B $1,56 \times 10^{-1}$
 - C $0,156 \times 10^1$
 - D $15,6 \times 10^1$
- (1)

1.7 A cylindrical cake has a diameter of 220 mm and a height of 100 mm
If the cake is cut into 12 equal size slices, the volume of each slice will be:

$\left(\text{Use } \pi = \frac{22}{7} \right)$

- A $3\ 802\ 857\ \text{mm}^3$
 - B $1\ 267\ 619\ \text{mm}^3$
 - C $316\ 905\ \text{mm}^3$
 - D $15\ 211\ 429\ \text{mm}^3$
- (1)

1.8 There are 3 green and 2 red balls in a bag. Two balls are drawn consecutively and then replaced after each ball is drawn. The probability that both balls will be green is:

- A 0
 - B 100%
 - C $\frac{3}{5}$
 - D $\frac{9}{25}$
- (1)

1.9 If 12 workers clean up a certain stretch of the Swarkops River in 4 days, then 8 workers would have cleaned the same stretch in ...

- A 2 days.
- B 24 days.
- C 6 days.
- D 3 days.

(1)

1.10 In $\triangle PQR$, QR is extended to S.

The size of $\angle Q$ is:

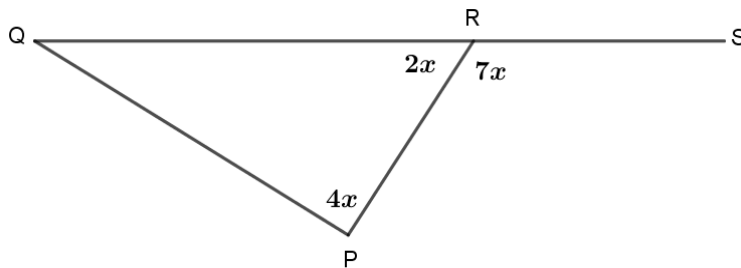

- A 40°
- B 20°
- C 140°
- D 60°

(1)
[10]

QUESTION 2

2.1 Write 1 042 000 000 in scientific notation. (1)

2.2 Simplify:

2.2.1 $3z^2 - \left(4\frac{2}{3}z^3 \div \frac{7z}{2}\right)$ (3)

2.2.2 $2(x-3)^2 - 3(x+1)(2x-5)$ (3)

2.2.3 $\left(\frac{2x^{-1}y}{3y^2}\right)^{-2}$ (3)

2.2.4
$$\frac{\sqrt{169x^6} \times \left(\frac{y}{p^{99}q}\right)^0}{\sqrt[3]{x^{12}}}$$
 (3)

2.3 Factorise completely:

2.3.1 $ax^2 - 5ax + 6a$ (3)

2.3.2 $(2x-3y) + (3y-2x)x^2$ (3)

2.4 Solve for x :

2.4.1 $\frac{x}{2} + \frac{2x+3}{3} = 1$ (2)

2.4.2 $x^2 + x = 12$ (2)

2.4.3 $5^{x+2} = \frac{1}{25}$ (2)

[25]

QUESTION 3

3.1 Consider the following shapes and answer the questions that follow.

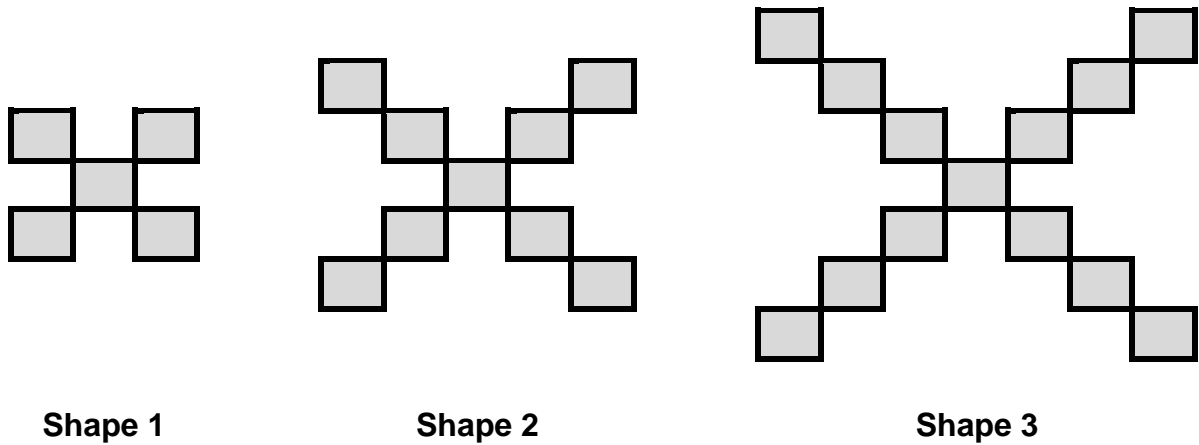

3.1.1 Refer to the table below and write down the values of q and r .

Shape	1	2	3	4	...	r
Number of rectangles	5	9	13	q	...	101

 (1)

3.1.2 Determine the general rule (T_n) of the pattern. (2)

3.1.3 Hence, determine which shape will have 205 rectangles. (2)

3.2 Given the following number pattern: 2; 5; 10; 17; ...

3.2.1 Provide a rule to describe the relationship between the numbers in this number pattern. (2)

3.2.2 Use your rule to find the 10th term in this number pattern. (2)

3.3 Read the flow diagram below and answer the questions that follow.

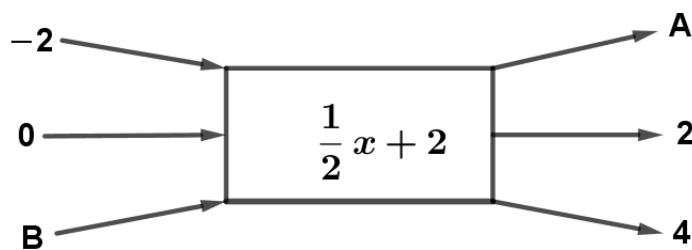

3.3.1 What is the output value in A ? (2)

3.3.2 What is the input value in B ? (2)

3.4 Use the table below to answer the questions that follow.

x	-3	-2	-1	0	...	q
y	-10	-7	-4	-1	...	8

3.4.1 Find the rule in the form $y = \dots$ (2)

3.4.2 Determine the value of q . (2)

3.5 A straight-line graph is defined by $y = -x + 3$.

3.5.1 Determine the X -intercept of the graph. (1)

3.5.2 Draw the graph showing all your intercepts with the axes. Use ANNEXURE 1. (3)

3.6 The following graph shows the number of packets of sweets that a shop owner sold during a week.

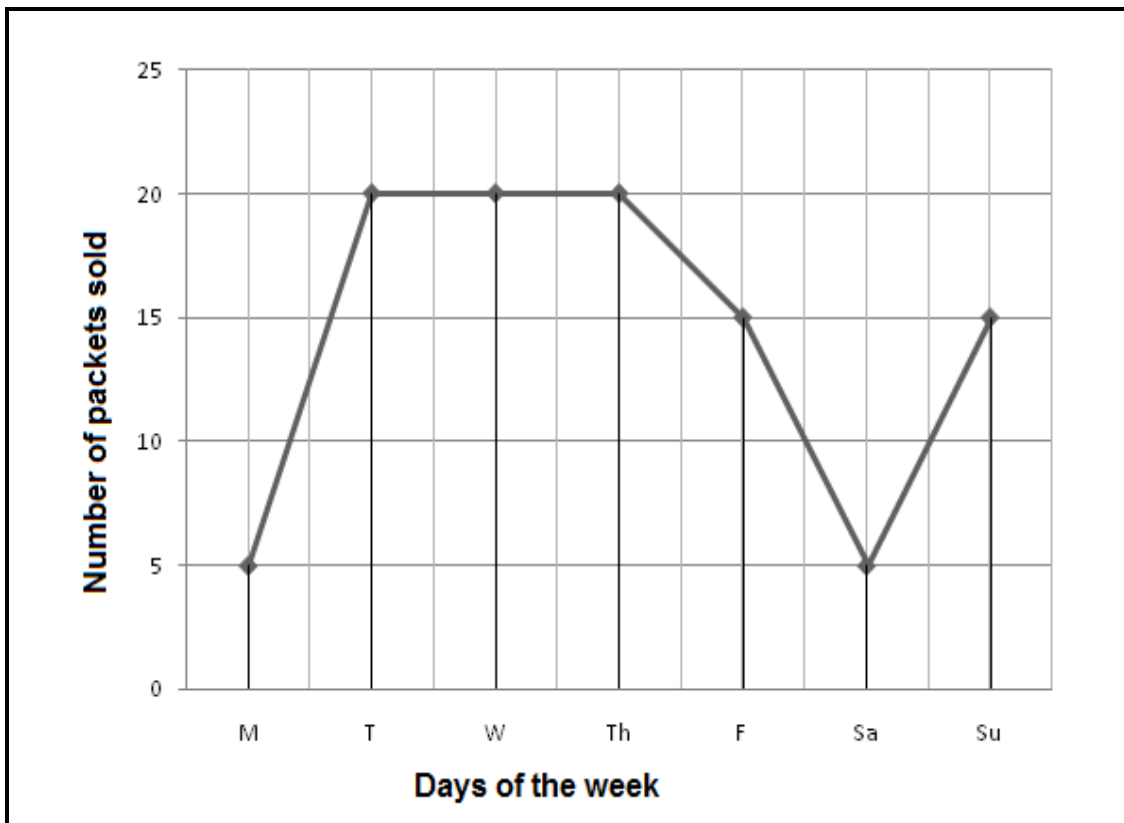

3.6.1 On which days was there an increase in sales? (1)

3.6.2 What was the amount of the increase shown on the days mentioned in QUESTION 3.6.1? (1)

3.6.3 On which days was there a decrease in sales? (1)

3.6.4 Was the decrease constant or did it vary? (1)

3.6.5 What happened from Tuesday to Thursday regarding the number of packets sold? (1)

[26]

QUESTION 4

- 4.1 Dhanielle invests R 1 800 for 5 years at r % simple interest per annum. The interest on the investment is R720. Calculate the interest rate. (3)
- 4.2 A playground is in the form of a rectangle with the length 1 m longer than the breadth. A new rectangular playground is planned that will be 3 m longer than the original length and with a breadth 1 m shorter than that of the original breadth. Determine the difference in perimeter of the two playgrounds. (5)
- 4.3 Lenneth drives from Cape Town to Worcester, a distance of 120 km, in 1 hour 30 minutes. He then drives from Worcester to Stellenbosch, a distance of 90 km, in 1 hour. Calculate the average speed at which he travelled. (4)

[12]

QUESTION 5

- 5.1 In the diagram below $AC \parallel HF$ and $BF \parallel CD$. $\angle CBF = 85^\circ$ and $\angle GFH = 50^\circ$
Find with reasons, the size of:

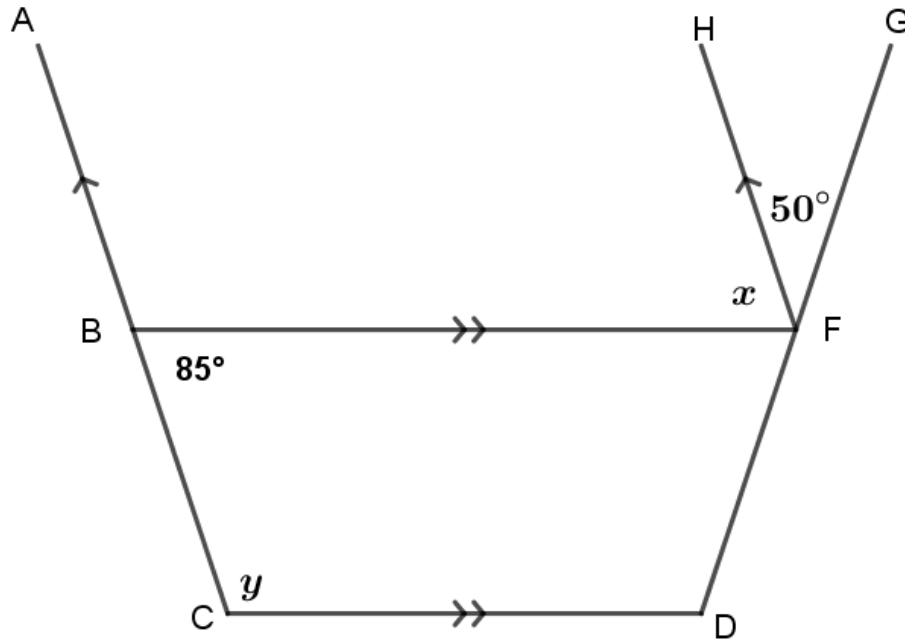

5.1.1 x (2)

5.1.2 y (2)

- 5.2 In the diagram below is $\triangle MNO$ with $MN \parallel QP$, $\angle OMN = 55^\circ$, $\angle QPO = 3x + 40^\circ$ and $\angle MON = 2x - 5^\circ$.

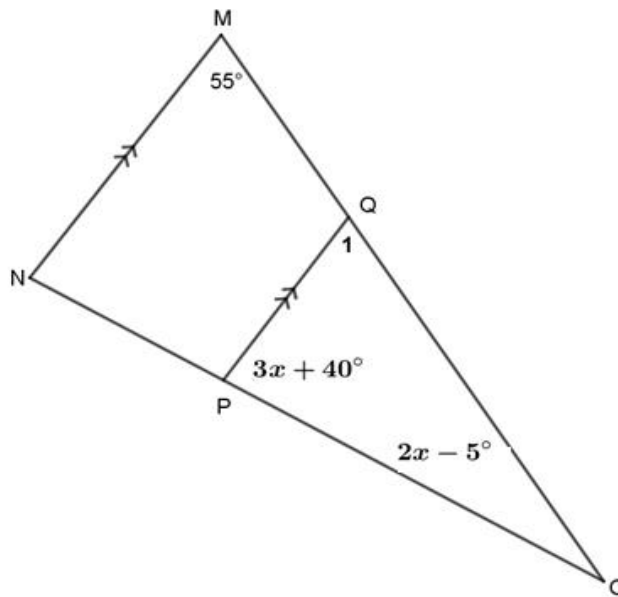

- 5.2.1 Calculate the value of x . Give reasons for your answer. (4)
- 5.2.2 Calculate the actual size of $\angle MON$. (2)
- 5.3 The diagram below is rhombus ABCD with diagonal BD. AB is extended to E and $\hat{A} = 70^\circ$.

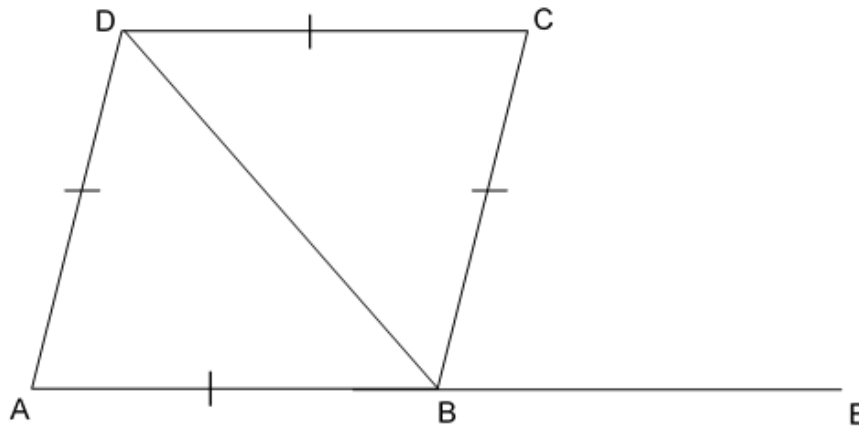

- 5.3.1 Calculate, with reasons, the size of $\angle ADB$. (3)
- 5.3.2 Calculate, with reasons, the size of $\angle ADC$. (3)
- 5.3.3 Calculate, with reasons, the size of $\angle DBE$. (2)
- 5.3.4 Give a reason why $\angle ABD = \angle BDC$. (1)

[19]

QUESTION 6

6.1 In parallelogram MNOP with diagonal PN, $MN \parallel PO$ and $MP \parallel NO$.

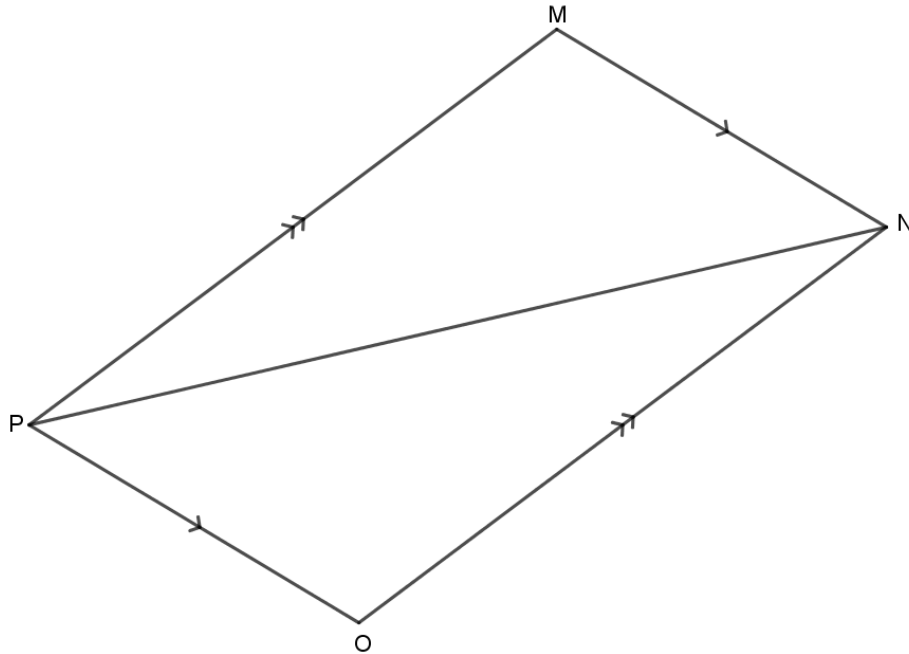

Use congruency to prove that $PM = NO$.

(5)

6.2 In the diagram below, $AC \parallel DF$, $AB \parallel CF$, $BE = 8$ cm, $EC = 10$ cm and $CF = 5$ cm.

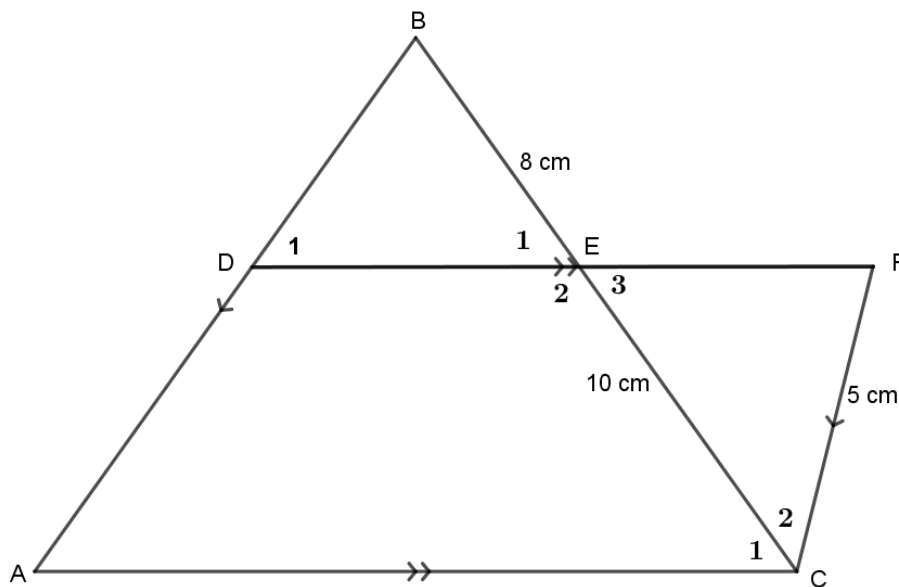

6.2.1 Prove that $\triangle DBE \parallel \triangle FCE$.

(4)

6.2.2 Hence, determine the length of DB.

(3)

[12]

QUESTION 7

- 7.1 A water pipe is cast in concrete. The inner radius of the pipe is 15 centimetres and the outer radius is 18 centimetres. The height of the pipe is 120 centimeters.

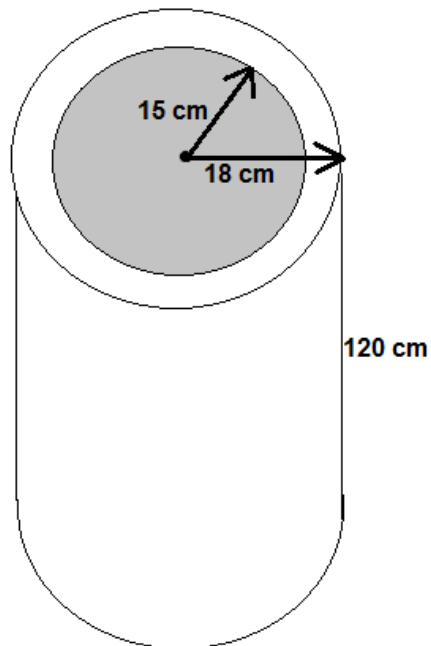

- 7.1.1 Determine, correct to TWO decimal places, the total surface area in cm^2 if the pipe is open on both ends. (4)
- 7.1.2 Determine, correct to TWO decimal places, the volume in cm^3 of concrete needed to make a 120-centimetre-long pipe. (4)

- 7.2 In the diagram is an isosceles triangle ABC with $BC = 5$ cm and height $BF = 4$ cm. Square $ACDE$ has an enclosed circle touching all four of its sides.

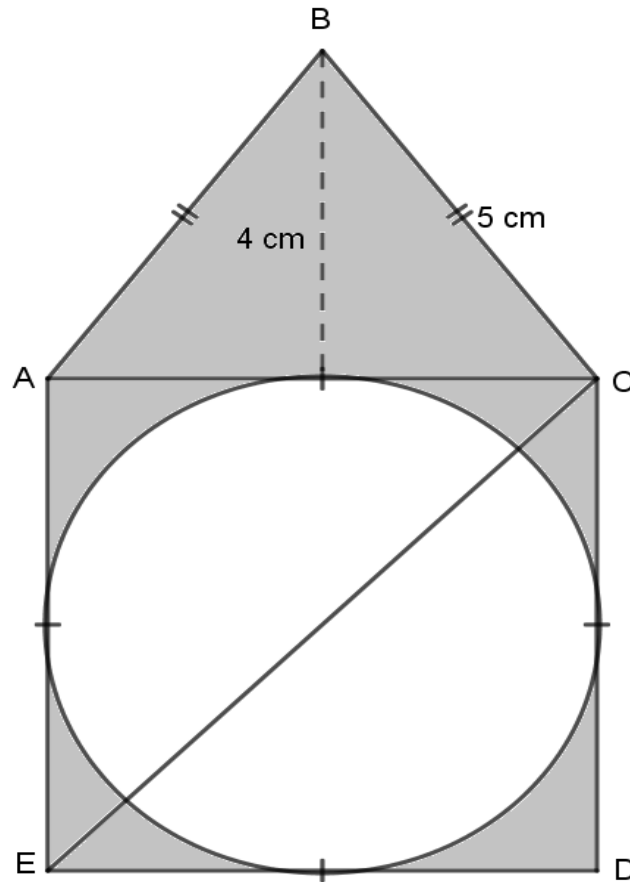

Calculate the shaded area in the diagram, correct to two decimal places, if the height of the triangle is $h = 4$ cm.

(5)
[13]

QUESTION 8

Use the diagram given below and answer the following questions.

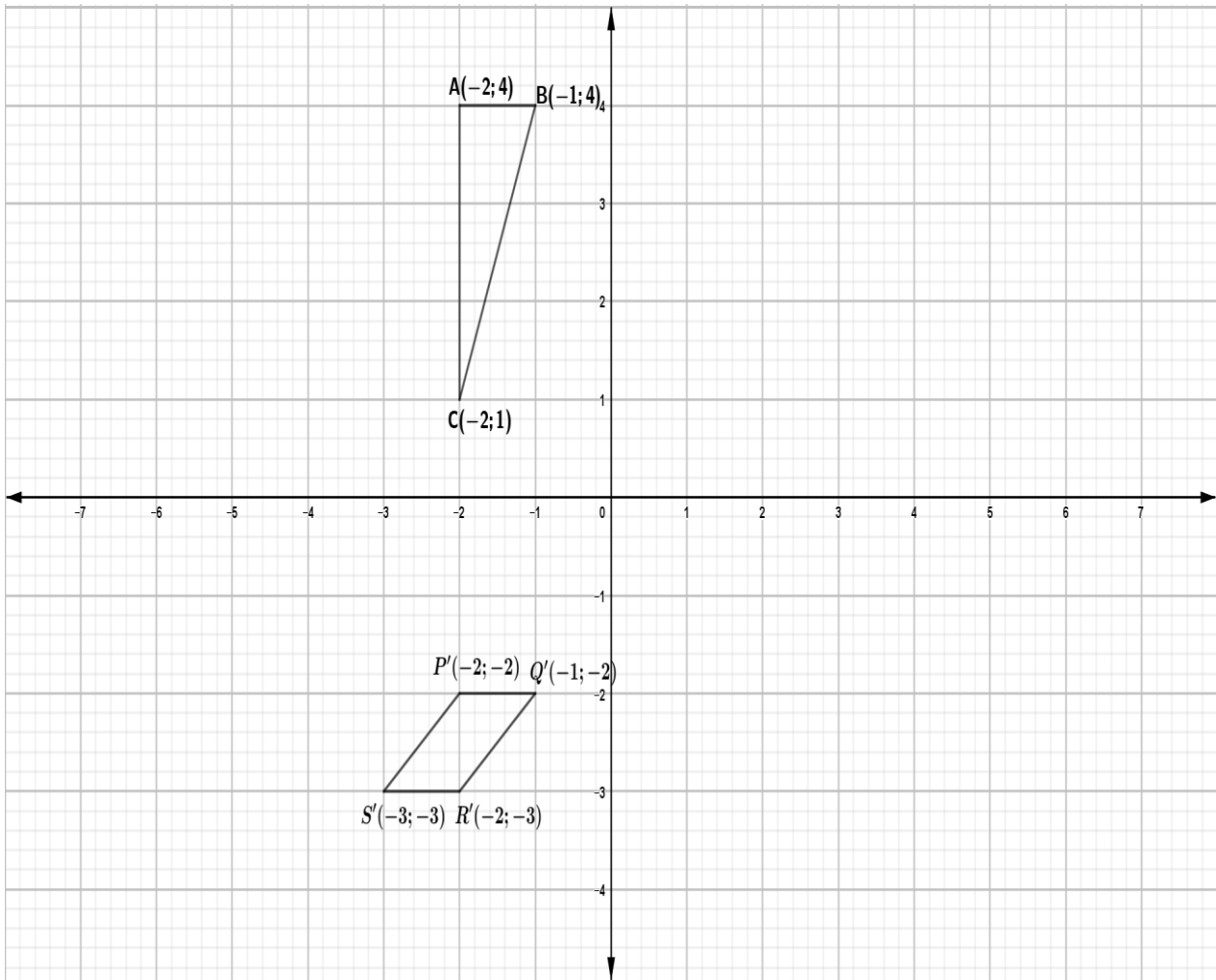

- 8.1 ΔABC is reduced by a scale factor of $\frac{1}{2}$ about the origin.
Draw $\Delta A'B'C'$ on ANNEXURE 2. (3)
- 8.2 Reflect ΔABC in the line $y = x$ to form $\Delta A''B''C''$.
Draw $\Delta A''B''C''$ on ANNEXURE 2. (3)
- 8.3 Quadrilateral P'Q'R'S' is the image of quadrilateral PQRS being translated according to the following rule: $(x; y) \rightarrow (x + 1; y - 2)$
Draw the original quadrilateral PQRS on ANNEXURE 2. (4)

[10]

QUESTION 9

- 9.1 All the Grade 9 learners of a school were asked whether they had cellphones or not. If they had one, they also had to indicate whether they had it on a contract, with the phone being paid for by the parent/guardian or whether it was pre-paid. Their responses are shown in the table below:

	Contract	Pre-paid	No cellphone	Total
Boys	a	57	24	100
Girls	23	b	37	150
Total	42	147	c	250

- 9.1.1 Calculate the value of **a**, **b** and **c** in the table. (2)
- 9.1.2 If a Grade 9 learner is chosen at random from this school, what is the probability that this learner will be:
- (a) A girl? (2)
- (b) A boy owning a cellphone? (2)
- (c) A learner with no cellphone? (2)
- 9.2 The mean monthly salary of all the staff at company Gringos is R7 550 per month, but the median salary is R5 225.
- 9.2.1 Explain and give a reason why the two summary statistics are so different. (3)
- 9.2.2 Which summary statistic gives a better idea of the salaries at the company? Give a reason for your answer. (2)

[13]**TOTAL: 140**

ANNEXURE 1

QUESTION 3.5.2

NAME: _____

SURNAME: _____

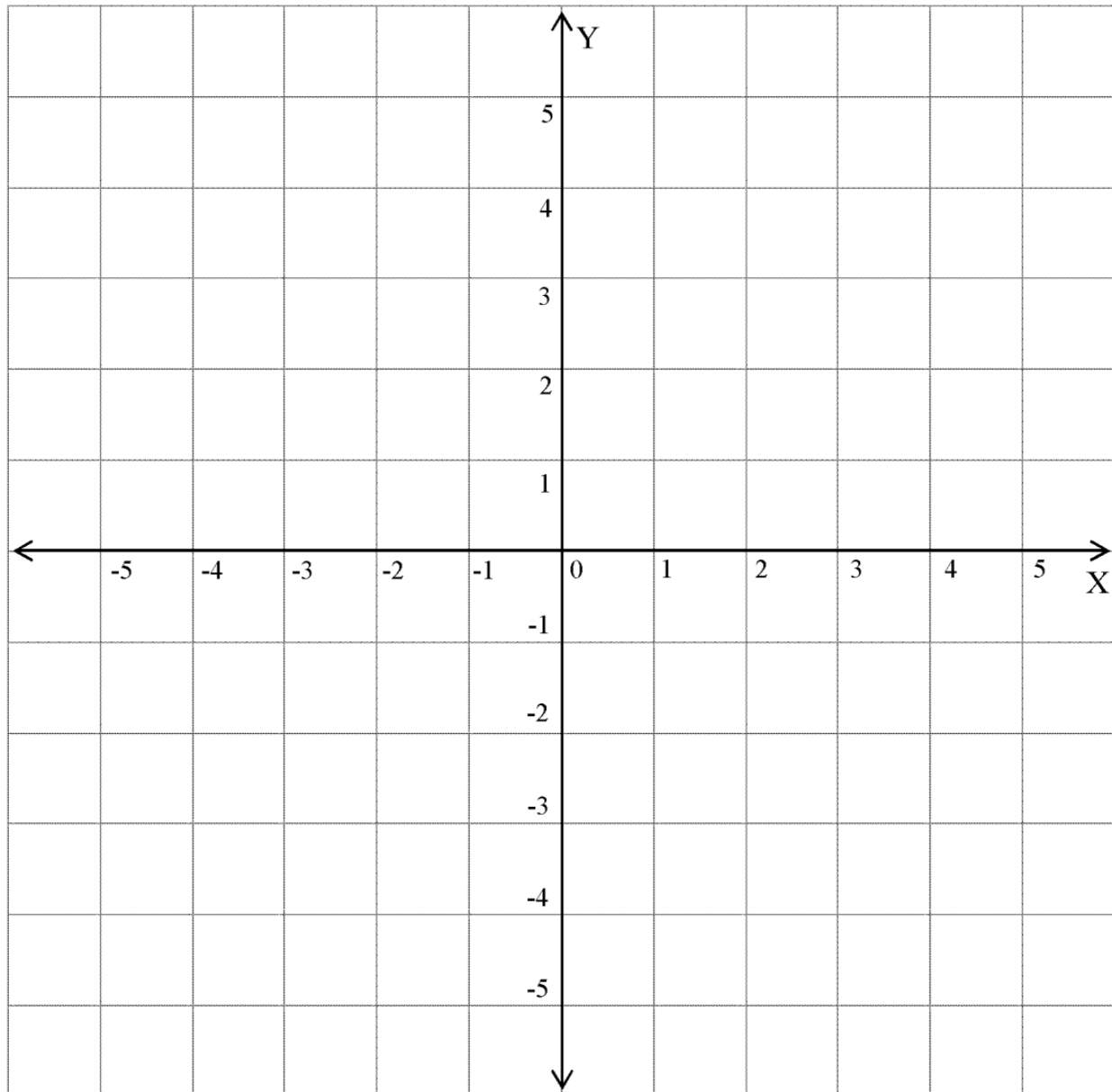

ANNEXURE 2

QUESTION 8.1; QUESTION 8.2 and QUESTION 8.3

NAME: _____

SURNAME: _____

