



GAUTENG PROVINCE
EDUCATION
REPUBLIC OF SOUTH AFRICA

**GAUTENG DEPARTMENT OF EDUCATION
PROVINCIAL EXAMINATION**

JUNE 2016

GRADE 10

PHYSICAL SCIENCES

(PAPER 1)

TIME: 90 minutes

MARKS: 100

11 pages + 1 data sheet and 1 answer sheet

PHYSICAL SCIENCES (Paper 1)	GRADE 10	2
--	-----------------	----------

**GAUTENG DEPARTMENT OF EDUCATION
PROVINCIAL EXAMINATION**

**PHYSICAL SCIENCES
(Paper 1)**

TIME: 90 minutes

MARKS: 100

INSTRUCTIONS AND INFORMATION

1. This question paper consists of SEVEN questions. Answer ALL the questions.
2. Remove the ANSWER SHEET on page 13, write your name on it and hand in with your answer book.
3. You may use a non-programmable calculator.
4. You may use appropriate mathematical instruments.
5. You are advised to use the attached DATA SHEETS on Page 12.
6. Number your answers according to the numbering system used in this question paper.
7. Write neatly and legibly.
8. Start the answer to each question on a NEW page in the ANSWER BOOK.
9. Leave ONE line open between two sub-questions, for example between Question 2.1 and Question 2.2.
10. Show ALL formulae and substitutions in ALL calculations.
11. Round-off your final numerical answers to a minimum of TWO decimal places where needed.
12. Give brief motivations, discussions, et cetera where required.

SECTION A

QUESTION 1

Four options are provided as possible answers to each of the following questions. Each question has only ONE correct answer. Circle only the letter (A – D) next to the question number (1.1 – 1.10) on the provided ANSWER SHEET.

1.1 Consider the following diagram of a wave with a frequency of 12 Hz.

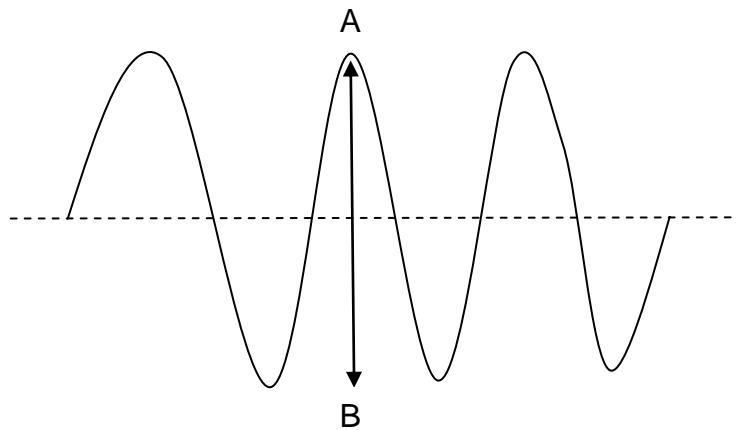

The distance AB can be described as ...

- A the wavelength.
- B the amplitude.
- C the period.
- D twice the amplitude.

(2)

1.2 Ultrasound is used by doctors to study an unborn foetus. The principle of ultrasound scanning is based on ...

- A resonance.
- B reflection.
- C refraction.
- D superpositioning.

(2)

1.3 What would a drummer do to make the sound of a drum produce a note of higher pitch? He should ...

- A hit the drum harder.
- B hit the drum less hard.
- C tighten the drum skin.
- D loosen the drum skin.

(2)

1.4 Five waves in a slinky require 1,5 seconds to move past a fixed point. The length of each wave is 0,2 m. The period is ...

- A 0,3 s.
- B 3,3 s.
- C 0,04 s.
- D 7,5 s.

(2)

1.5 If a wave has a frequency of 0,6 Hz and a wavelength of 10 m what would be its speed?

- A 8 m.s^{-1}
- B 16 m.s^{-1}
- C 6 m.s^{-1}
- D 40 m.s^{-1}

(2)

1.6 A glass rod is charged positively by rubbing it with a silk cloth. During this process ...

- A electrons are transferred from the glass rod to the silk cloth.
- B electrons are transferred from the silk cloth to the glass rod.
- C protons are transferred from the silk cloth to the glass rod.
- D protons are transferred from the glass rod to the silk cloth.

(2)

1.7 Which of the following arrangements will result in a total resistance of 4Ω if the resistors are all 4Ω ?

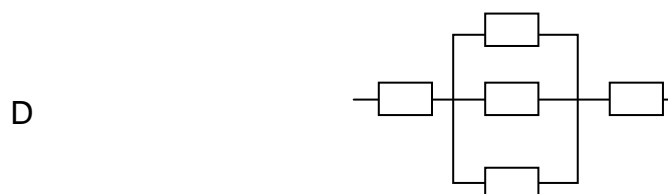
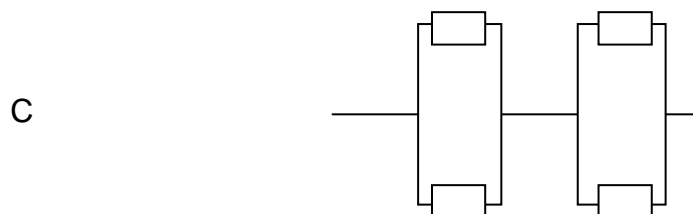
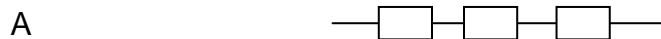

(2)

1.8 Which of the following statements regarding the effects of geomagnetic storms is true?

Geomagnetic storms cause ...

- A induced currents in power lines and pipelines that result in power failures.
- B disruption of communications and navigation systems.
- C damage to satellites.
- D shifts in the geographical poles of the earth. (2)

1.9 Two identical metal spheres on insulated stands carry charges of X C and -5 C respectively. They are brought into contact with each other and separated again. Each sphere now has a charge of +3 C. The value of X is ...

- A -5 C
- B +5 C
- C 11 C
- D +8 C (2)

1.10 The unit in which electrical current is measured, is ...

- A coulomb.
- B ampere.
- C volt.
- D ohm. (2)

TOTAL SECTION A: 20

SECTION B

QUESTION 2

2.1 Study the following diagram and label A – D.

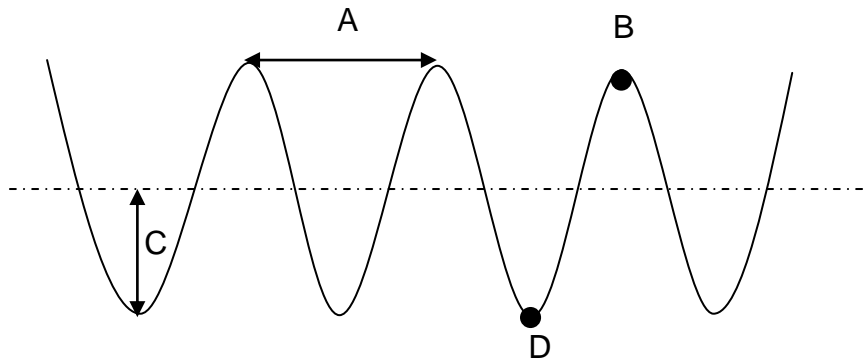

(4)

2.2 The diagram below shows two waves, **A** and **B**, of the same wavelength but with different amplitudes, crossing each other.

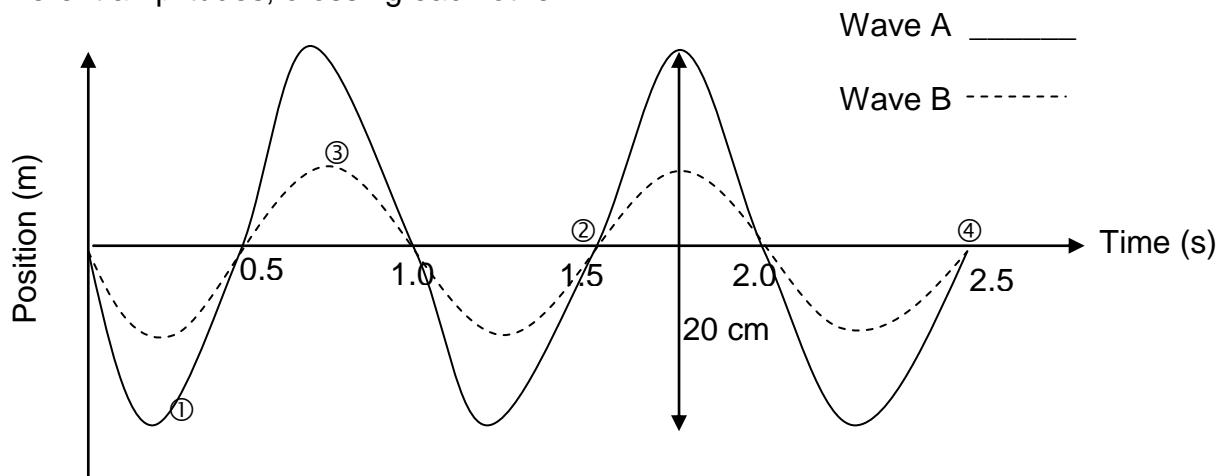

2.2.1 What type of wave is represented by the pattern above? (1)

2.2.2 Which circled number (1 – 4) points represent one cycle? (1)

2.2.3 Determine the following for Wave A:

(a) Frequency (2)

(b) Period (2)

(c) Amplitude (3)

2.2.4 Draw the shape of the resulting wave as the two waves (**A** and **B**) cross. On your diagram, show the resulting amplitude. (3)

2.2.5 Which wave property is illustrated in Question 2.2.4? (1)

2.2.6 Name and describe the principle used to answer Question 2.2.4. (3)

[20]

P.T.O.

QUESTION 3

- 3.1 On the ANSWER SHEET, label the given wave as **M**. On the same sketch, draw a wave travelling at the same speed with half the frequency of the given wave. Label it **P**.

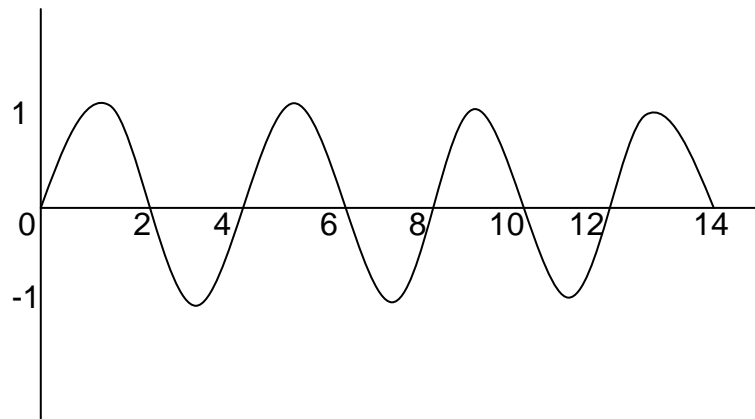

(4)

- 3.2 Bats have very poor vision and use echo-location to find their way. The frequency produced by bats is 100 kHz. If the speed of sound in the cave is $345 \text{ m}\cdot\text{s}^{-1}$, how deep is the cave if the bat makes peeping sounds that return to the bat after 0,15 s? (3)
- 3.3 Draw a sound wave and label it with amplitude, compression and rarefaction. (4)

[11]

QUESTION 4

- 4.1 What makes electromagnetic waves unique when compared to other waves? (2)
- 4.2 Explain how electromagnetic waves originate. (3)
- 4.3 If a microwave oven radiates with a wavelength of 100 mm, calculate the energy of a photon inside the microwave oven. (4)
- 4.4 The following table shows a few electromagnetic waves and their corresponding wavelengths.

Radiation	Wavelength (m)
X-rays	$2,11 \times 10^{-10}$
Ultraviolet light	$3,00 \times 10^{-7}$
Visible light	$5,13 \times 10^{-6}$
Infrared	$4,05 \times 10^{-5}$
Medium-wave radio waves	$6,21 \times 10^2$

- 4.4.1 Which of the rays in the table has the highest penetrating ability? Give a reason for your answer. (2)
- 4.4.2 Electromagnetic waves from an unknown source are received and it is discovered that a photon of this radiation has an energy of $6,63 \times 10^{-19}$ J. Use a calculation to determine the kind of electromagnetic wave this is. (4)
- 4.5 Ultraviolet lamps are often used in butcheries even though they have the potential to damage people's eyes.
- 4.5.1 Explain how UV light can cause damage to one's eyes. (1)
- 4.5.2 Explain the reason for using UV light in butcheries. (1)
- [17]**

QUESTION 5

In the diagram below, steel paper clips **A** and **B** are attached to a string which is attached to a table. The paper clips remain suspended beneath a magnet.

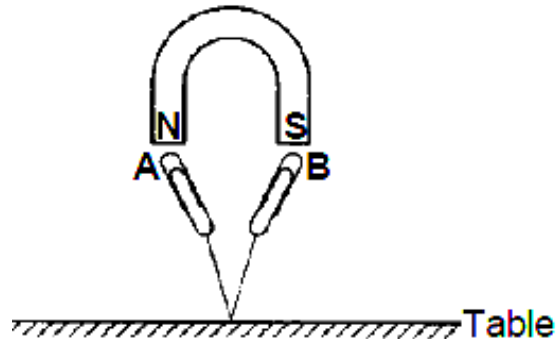

- 5.1 Define the term *magnetic field*. (2)
- 5.2 What is the polarity of the top end of paper clip **A**, North or South? (1)
- 5.3 Two bar magnets are placed close to one another as shown in the diagram below



Complete the magnetic field pattern between the two magnets, on the ANSWER SHEET. (3)

- 5.4 If the distance between the two poles is increased, will the magnetic force between the magnets, INCREASE, DECREASE or REMAIN THE SAME? Explain your answer. (3)
- [9]**

QUESTION 6

Two identical insulated, graphite-coated polystyrene spheres are suspended from threads. The spheres are held a small distance apart. The charges on the Spheres **P** and **Q** are $-2,4 \text{ nC}$ and $+5,6 \text{ nC}$ respectively.

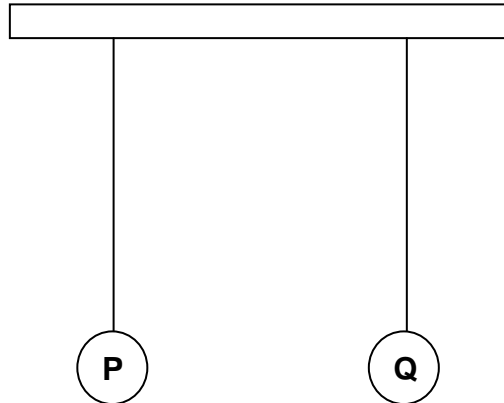

When the spheres are released they move towards each other.

6.1 Explain why the spheres move towards each other when they are released. (2)

The two spheres now touch each other and then separate.

6.2 Calculate the charge on each sphere after they touch and separate. (2)

6.3 Write down the number of electrons found on Sphere **P** after it touched **Q** and separated. (2)

6.4 Which way will electrons move? Write only **from P to Q**, or **from Q to P**, or **neither way**? (1)

6.5 Explain your answer to Question 6.4. (2)

[9]

QUESTION 7

Learners conducted an experiment to determine whether the effective resistance is lower when resistors are connected as current dividers than when they are connected as potential dividers.

CIRCUIT A

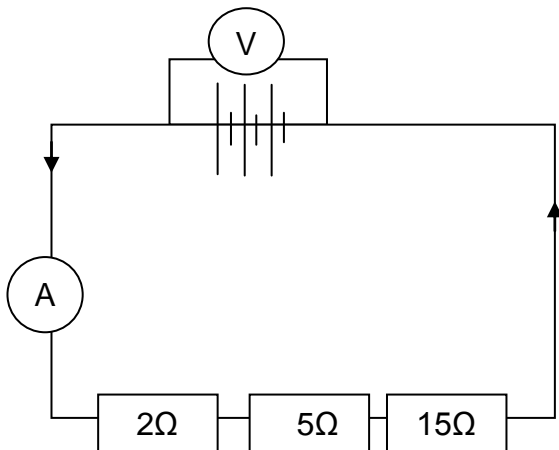

CIRCUIT B

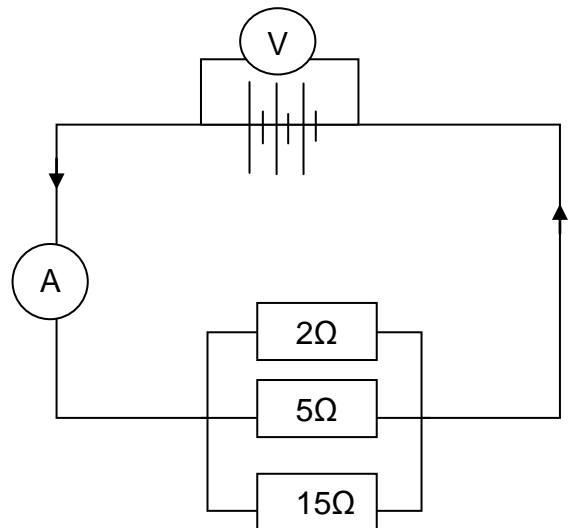

- 7.1 Formulate an aim for this experiment. (2)
- 7.2 Identify the
 - 7.2.1 Controlled variable (1)
 - 7.2.2 Independent variable (1)
- 7.3 Give a reason why the ammeter is connected in the manner that it is in the diagram. (1)
- 7.4 Calculate the total resistance of Circuit B. (3)
- 7.5 A charge of 2,3 C flows through the filament of a bulb in 7 minutes. Calculate ...
 - 7.5.1 the electric current passing through the filament. (3)
 - 7.5.2 the potential difference if 30 J of energy is required to carry the charge from one point to another. (3)

[14]

TOTAL SECTION B: 80

TOTAL: 100

END

**DATA FOR PHYSICAL SCIENCES GRADE 10 PAPER 1
(PHYSICS)**

TABLE 1: PHYSICAL CONSTANTS/TABEL 1: FISIESE KONSTANTES

NAME / NAAM	SYMBOL / SIMBOOL	VALUE / WAARDE
Acceleration due to gravity <i>Swaartekragversnelling</i>	g	9,8 m·s ⁻²
Speed of light in a vacuum <i>Spoed van lig in 'n vakuum</i>	c	3,0 x 10 ⁸ m·s ⁻¹
Planck's constant <i>Planck se konstante</i>	h	6,63 x 10 ⁻³⁴ J·s
Charge on electron <i>Lading op elektron</i>	e	-1,6 x 10 ⁻¹⁹ C
Electron mass <i>Elektronmassa</i>	m _e	9,11 x 10 ⁻³¹ kg

TABLE 2: FORMULAE / TABEL 2: FORMULES

MOTION / BEWEGING

$v_f = v_i + a \Delta t$	$\Delta x = v_i \Delta t + \frac{1}{2} a \Delta t^2$
$v_f^2 = v_i^2 + 2a \Delta x$	$\Delta x = \left(\frac{v_f + v_i}{2} \right) \Delta t$

WORK, ENERGY AND POWER / ARBEID, ENERGIE EN DRYWING

$U = mgh$ or/of $E_p = mgh$	$K = \frac{1}{2} mv^2$ or/of $E_k = \frac{1}{2} mv^2$
-----------------------------	---

WAVES, SOUND AND LIGHT / GOLWE, KLANK EN LIG

$v = f \lambda$	$T = \frac{1}{f}$
$E = hf$ or/of $E = h \frac{c}{\lambda}$	

ELECTRIC CIRCUITS / ELEKTRIESE STROOMBANE

$Q = I \Delta t$	$\frac{1}{R_p} = \frac{1}{R_1} + \frac{1}{R_2} + \dots$
$R_s = R_1 + R_2 + \dots$	$V = \frac{W}{q}$

ANSWER SHEET

NAME OF LEARNER: _____ GRADE 10: _____

SECTION A

QUESTION 1

1.1	A	B	C	D
1.2	A	B	C	D
1.3	A	B	C	D
1.4	A	B	C	D
1.5	A	B	C	D
1.6	A	B	C	D
1.7	A	B	C	D
1.8	A	B	C	D
1.9	A	B	C	D
1.10	A	B	C	D

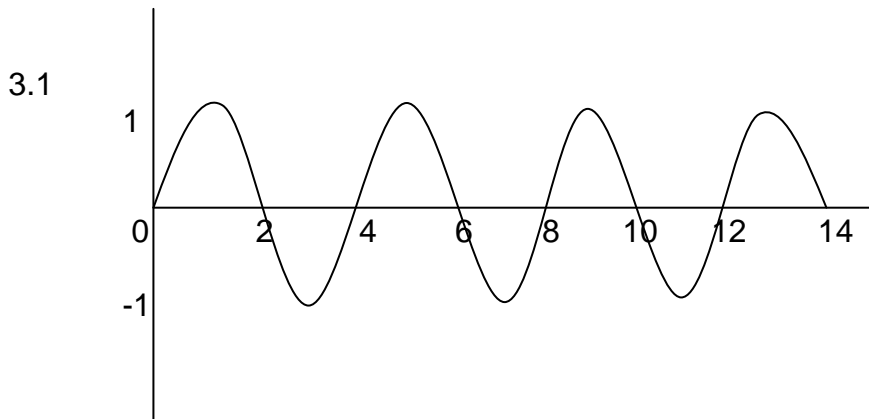

5.3

N S

S N